

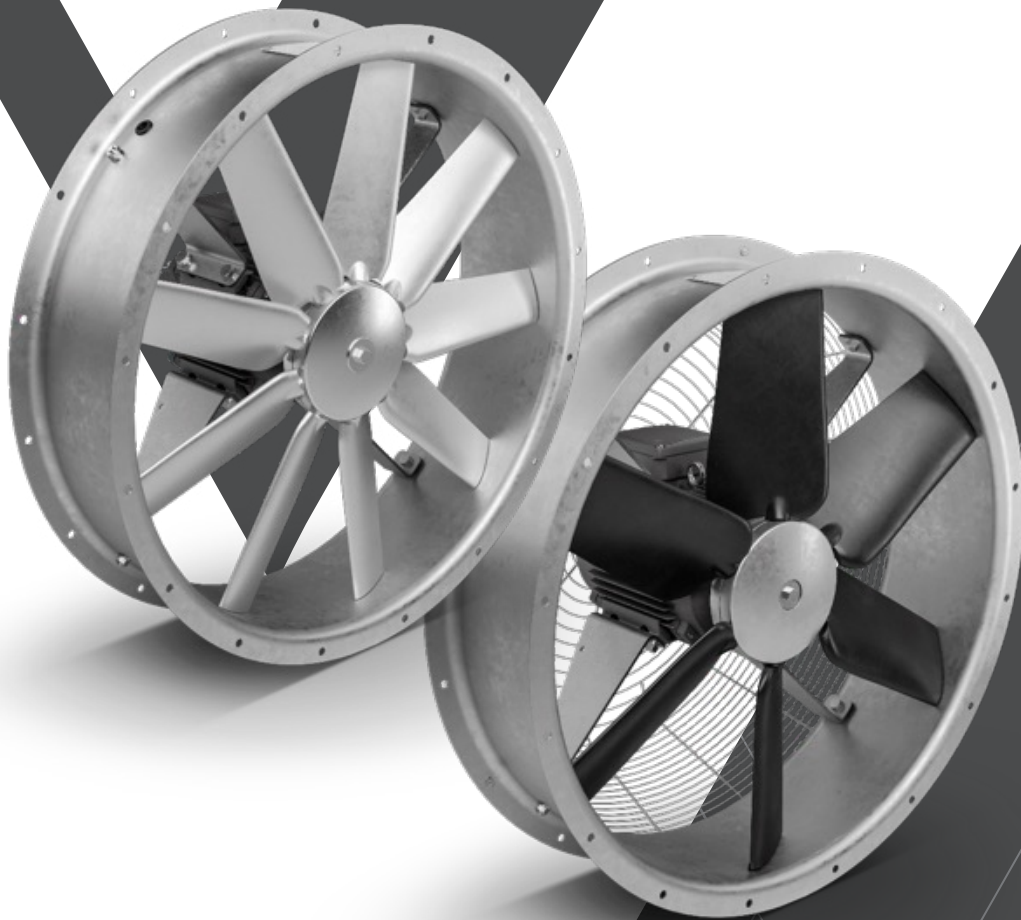

## **INDUSTRIAL COOLING FAN**

Safety, installation and  
maintenance instructions  
Part Number 915960



## CONTENTS

## PAGE

### STANDARD VENTILATION FANS

1 SAFETY .....	4
2 INTRODUCTION & PURPOSE - GENERAL .....	4
3 STORAGE & HANDLING .....	5
4 MECHANICAL INSTALLATION .....	5
5 ELECTRICAL INSTALLATION & OPERATION .....	6
5.1 - OVERHEAT PROTECTION .....	7
5.2 - BEARING TEMPERATURE, VIBRATION & LEVEL MONITORING SENSORS .....	7
5.3 - ANTI-CONDENSATION HEATER .....	7
5.4 - SWITCH-ON .....	7
6 MAINTENANCE .....	8
6.1 - FIXINGS .....	8
6.2 - LUBRICATION .....	8
6.3 - INFREQUENT USE .....	8
7 OVERHAUL / EXTENDED MAINTENANCE .....	8
8 FAULT FINDING .....	9
8.1 - ELECTRICAL .....	9
8.2 - MECHANICAL .....	9
9 DISPOSAL .....	10
10 EUROPEAN MACHINERY DIRECTIVE 2006/42/EC 10 .....	10
DECLARATION OF CONFORMITY .....	10
EC DECLARATION OF CONFORMITY .....	11

### TABLE

1 ROUTINE MAINTENANCE PROCEDURES .....	12
--	----

### FIGURES





1 WIRING DETAIL - THREE PHASE FANS WITH DUCT MOUNTED TERMINAL BOX .....	13
2a DRAWINGS OF FAN COMPONENTS WITH FIXING METHODS SHOWN .....	14
2b DRAWING OF TORQUE SETTINGS FOR FIXINGS (DRAWING NO: D248284) .....	15

**THIS LEAFLET MUST BE PASSED TO THE USER  
TO ENABLE THE FAN TO BE MAINTAINED IN A SAFE CONDITION.**

# THIS LEAFLET MUST BE PASSED TO THE USER TO ENABLE THE FAN TO BE MAINTAINED IN A SAFE CONDITION.

## 1. SAFETY

Warning and safety information relevant to specific operations are contained within each section. The following warning or advice categories are used:

-  **DANGER!** Failure to follow these instructions may result in serious injury or death to the user in addition to serious damage to the equipment.
-  **WARNING!** Failure to follow these instructions may result in minor injury or damage to the equipment.
-  **CAUTION!** Failure to follow these instructions may result in malfunction or damage to the equipment.
-  **NOTE!** Additional instructions to consider.

## 2. INTRODUCTION & PURPOSE - GENERAL

The Industrial Cooling Fans are highly efficient air movement products, designed to operate within a temperature range of -40° to +60°C (suitable for starting at -40°C). When operating at low temperatures, ice formation on the fan assembly must be prevented.

Each fan assembly has been manufactured specifically to fulfil the requirement of the installation for which it was designed. No deviation from the original requirement must be implemented without referring to Woods Air Movement head office (located in Colchester, UK). Any queries regarding safety or operating problems must be referred to your local Woods Air Movement office, sales centre or representative, together with full fan/motor nameplate details. Should a fan failure occur whilst the product is under warranty, the Woods Air Movement service centre in Colchester must be contacted before any repair work is undertaken.

Only approved, qualified personnel familiar with the assessment of hazards and risks associated with fans, and with the use of tools and test equipment required to service such fans, should install, operate, and maintain the product. If the installer or user is unable to understand the information in this manual or has any doubt that safe and reliable installation, operation, and maintenance of the equipment can be assured, Woods Air Movement or their representative must be contacted for advice.

**If speed control is to be provided by means of a frequency inverter, please seek drive selection and compatibility advice from Woods Air Movement.**

-  **CAUTION!** The motor should not be removed from the product or modified in any way.

## 3. INSPECTION, STORAGE & HANDLING



**WARNING!** When storing fan assemblies, please ensure that access by unauthorised personnel is prevented by using guards, barriers, or secure premises, so that fan impellers, which may be rotating (wind milling), do not present a hazard.

Check immediately on receipt that the fan is as ordered and that it has not been damaged in transit.

Where the fan is delivered in a crate (or similar) the crate must be considered as a protective device for transit only.

The crate must not have other equipment stacked on top of it and it must not be stacked on top of other equipment. The crate structure must not be used as a lifting aid, unless otherwise indicated.

Where a fan is packed inside a crate, a fork-lift truck or similar must be used to transport the product. The fan must be stored in a safe, clean, dry, vibration free location. If such storage conditions are not available, the motor anti-condensation heater (where fitted) should be connected to an appropriate electrical power supply to prevent motor condensation forming, while the fan should be stored in an appropriate enclosure. Each month, the fan impeller should be given a manual rapid spin to help prevent grease from hardening and possible bearing brinelling. If the impeller must not remain in the same angular position after rotation.

When dismantling the crate to gain access to the fan assembly care must be taken to avoid injury from sharp edges, nails, staples, splinters, etc. If the fan is to be stored for 12 months or more, then the activities described in Section 6.3 should be carried out.

It is highly recommended that the fan is inspected by a member of the Woods Air Movement service team before commissioning is undertaken.

## 4. MECHANICAL INSTALLATION



**DANGER!** It is recommended that suitable safety guards form part of the installation. Advice on these, and similar safety devices, are available from Woods Air Movement.



**WARNING!** Where the fan is delivered in a crate (or similar), the crate must be considered as a protective device only and must not be used as a lifting aid unless clearly indicated otherwise.



**WARNING!** All lifting aids used during installation must be appropriately certified to carry the weight of the equipment being lifted.



**WARNING!** The correct protective clothing (including hard hats, eye protectors and ear defenders) should always be worn when working with and in the vicinity of the fan assembly.



**WARNING!** During lifting of the fan all personnel must be clear of the area below and around the suspended fan.



**NOTE!** Before fan assembly installation, check that no damage has occurred in transit, that there is no fan casing deformation, that the impeller rotates freely and that the fan and motor nameplate data complies with its required use. If the fan assembly has been stored for longer than a month please refer to Section 6.3.

Fan assemblies can sometimes be very heavy (depending on fan and motor size and any attached ancillary equipment), which can make them unwieldy during handling. They must therefore be lifted slowly to prevent damage or distortion. Proper precautions must be taken, and certified lifting aids used, to ensure that the fan is well supported and stable before lifting into position. Care must be taken when installing fans to ensure that the product orientation is correct in relation to direction arrows which indicate direction of air movement and impeller rotation direction.

Flange holes or mounting feet holes can be used for lifting but more than one hole must be used to spread the load. If special lifting points are provided, they must be used. The fan must be installed such that it is correctly positioned in accordance with the required airflow direction. An airflow indication arrow is shown on the fan nameplate.

Sharp bends in the ductwork close to the fan must be avoided. Adequate room must be allowed around the fan for inspection and maintenance. When ancillary component parts are included in the fan assembly, such as anti-vibration mounts, silencers, bellmouths, air operated dampers, flexible connectors (and their clips), weather proofing, platforms, supports, chains, and harnesses, etc. they must be fully aligned before being bolted together so that no distortion or stress is placed on the equipment. **Air operated dampers must be installed downstream of the fan (on the fan discharge) to ensure that fan performance is not adversely impacted.**

The fan mounting and support structure must be strong and rigid enough to take the weight and operating forces of the fan and any other weight applied during installation. Consideration must be given to mitigation of vibration transmission. If vibration isolators are used they must be appropriate for the weight and thrust of the fan and must not be used to compensate for misaligned component fixing points. If any component parts do not easily fit together the root cause must be investigated and rectified.

Provision for drainage is provided in each motor end cover and electrical connection terminal box. The motor drain hole must be located at the lowest point of the motor when the fan is installed. Periodic inspections should be carried out to ensure there is not a general build up of condensation. The frequency will depend on the environmental conditions and should be recorded within maintenance records. To maintain the IP rating, the plugs must not be permanently removed.

After installation all packing materials must be disposed of in accordance with the instructions advised in Section 9.

## 5. ELECTRICAL INSTALLATION & OPERATION



**DANGER!** Before any work can be attempted, the fan assembly, its anti-condensation heater (if fitted) and all controls must be completely isolated from electrical supplies. Ensure that rotating parts are fully at rest.



**WARNING!** Before entering the area where the fan is installed, please ensure that all fumes, dust, toxic emissions, heat etc. have dispersed from the local environment, and that the fan blades are not likely to rotate.



**DANGER!** The fan assembly contains rotating parts and electrical connections which can be a danger and cause injury. If there is any doubt that a safe and reliable fan installation can be achieved Woods Air Movement or their representative must be contacted for advice.



**DANGER!** If the fan stops operating due to an overheat situation, the overheat protection thermostat may reset as the temperature cools and then automatically restart the fan if power is still applied.



**WARNING!** Always wear appropriate protective clothing (including hard hats, eye protectors and ear defenders etc.) when working in the vicinity of the fan assembly.

The electrical supply and electrical earthing must be connected to the terminal box by a qualified and competent electrician. It is good practice to fit a clearly marked isolator switch close to the product, preferably of the lockable type which will allow the operator or maintenance engineer to isolate the product from the electrical supply before working on the assembly. Alternatively, we recommend the use of a second clearly marked and accessible switch remote from the product to provide an enhanced level of safety when isolating the product during maintenance.

Sufficient cable length must be provided to allow for movement of the fan on its mountings.

A connection diagram providing wiring details is supplied with all fan assemblies (typically inside the terminal box lid). See Figure 1 on page 13 for wiring terminal details.

Electrical control circuit fuses must be correctly selected to carry the rated starting current as indicated on the motor or fan nameplate but should only be regarded as offering protection against wiring short circuits or earth faults. Fuses are not designed to provide overload protection. To provide full protection for the motor, a starter panel with overload protection must be used.

If the fan is to be powered by a variable frequency drive (inverter) then appropriately shielded cable and adequate earthing must be used. The use of effective voltage waveform filters is recommended.

Fans with a duct-mounted terminal box must have their electrical supply cables routed through an entry point in the side of the box. Unused entry points must be sealed with weatherproof plugs or grommets. Fans with a motor-mounted terminal box must also have its electrical supply routed through an entry point in the side of the terminal box.

Cables must be routed via a gland assembly. The gland assembly should be tightened sufficiently to hold the cable and provide a weatherproof seal, but it must not be over-tightened.

### 5.1 OVERHEAT PROTECTION

Thermostats are wired to separate terminals (K – K) within the terminal box; they operate by opening and closing with temperature and must be wired to directly disengage the motor start contactor. Other overheat protection options may have been requested - please refer to your local Woods representative.



**NOTE!** When a motor cools down, an over-heat protection device will reset. However the motor must not be allowed to start until the motor start contactor is manually reset.

### 5.2 BEARING TEMPERATURE AND VIBRATION MONITORING SENSORS

If monitoring sensors are fitted into the fan control system, then they must be wired to automatically switch the fan off if a fault occurs, or to provide a fault indication. If the fan is automatically switched off by a monitoring sensor the control system (via a PLC for example) must ensure that the fan is fully isolated from the electrical supply, so that it will not automatically reset and re-start.

### 5.3 ANTI-CONDENSATION HEATER

Anti-condensation heaters are terminated in a terminal box on the fan and must be externally wired to automatically receive the appropriate electrical supply when the motor is switched off. When the motor is switched on the anti-condensation heater is not required and thus must be automatically switched out of circuit.

### 5.4 SWITCH ON

Before switching on,

- confirm that the electrical supply is fully compliant with the requirement of the motor as detailed on the motor or fan nameplate,
- confirm that the fan is correctly installed,
- check all component parts and fixings are secure,
- confirm that safety guards are in place,
- check that no loose items or associated equipment are present in the vicinity,

Immediately after switch-on check that the direction of impeller rotation and air movement is correct,

- for three phase motors, if the rotation direction is incorrect, then this can be rectified by interchanging any two incoming phase connections of the electrical supply at the motor terminal block,
- check the assembly for smooth, low vibration running,
- check that the current consumption is within the full load current specified on the nameplate,
- the fan motor must not be repeatedly or rapidly switched on and off as this could cause overheating of the motor or its associated wiring connections.

### 5.5 OPERATION

Fans must not be operated above their maximum indicated speed or run where the fan is operating in a stalled or unstable condition.

Fans must not be run in reverse unless specific advice is sought from Woods Air Movement.

## 6. MAINTENANCE



**DANGER!** Before any maintenance work can be attempted, the fan assembly, its anti-condensation heater (if fitted), and all controls from electrical supplies must be completely isolated. Ensure that rotating parts are fully at rest and that fan blades are temporarily restrained to prevent rotation of the impeller.



**WARNING!** Before entering the area where the fan is installed, please ensure that all fumes, dust, toxic emissions, heat etc. have dispersed from the local environment.



**WARNING!** All lifting aids used during maintenance, and all lifting points utilized, must be adequately certified to carry the weight of the equipment being lifted.



**WARNING!** Always wear appropriate protective clothing (including hard hats, eye protectors and ear defenders etc.) when working in the vicinity of the fan assembly.

Fan assembly maintenance must be carried out by appropriately qualified and competent personnel using the correct tools and equipment. A regular maintenance schedule should be established, and a record kept. It is recommended that the maintenance activities given in Table 1 (page 12) are followed. Maintenance records are required to be documented throughout the warranty period.

Where the environment is particularly dirty, it may be necessary to reduce maintenance / service intervals. Internal and external fan surfaces may be cleaned with low pressure clean water and non-abrasive additives. Water or liquid cleaning agents must not be directed at motor drain holes, as this could cause liquid ingress.

After maintenance has been conducted and before the fan is re-started, always ensure that there are no loose items of equipment present in the vicinity of the fan, that all safety guards, chains, or steel ropes, etc., are properly secured into their original location, and that any temporary device used to stop the fan impeller from rotating has been removed.

### 6.1 FIXINGS

It is essential to ensure that all fan assembly fixings are secure. When examining and checking the security of fixings during routine maintenance (see Table 1 Items 11 and 12), any fixings which have locking devices fitted or are painted over, need not be disturbed if it can be seen that they are secure. Any locking devices that are disturbed during maintenance must be discarded and replaced with new identical devices. Thread forming screws must have locking compound applied when being reused. Any fixings which have no locking devices fitted and are not painted over, must be checked at 95% of their original torque setting to ensure that no unnecessary disturbance of the fixing has occurred. See Figure 2b (Page 15) for torque setting details. If in doubt, please contact Woods Air Movement for advice in relation to specific fixing torque values.

### 6.2 LUBRICATION

In addition to routine maintenance, motor bearings will, in the longer term, require attention. If motor bearings are greased through extended lubricators, then the required quantity of grease must periodically be applied in accordance with information stated on the fan or motor nameplate and/or as per any instructions provided. Only the approved grease type should be used, and it is essential that all traces of water and dirt are removed from around the grease points and that a clean grease gun is used. It is only necessary to apply a small amount of pressure to inject the specified quantity of grease. If a high pressure is required then the cause should be investigated.

Where motors require re-lubrication, a separate instruction is normally issued with each fan/motor configuration.

This gives details of lubrication intervals and well as the type and quantity of grease to be used. If further details are required, please contact Woods Air Movement directly.

## 6.3 INFREQUENT USE

If the fan assembly is used less frequently than once a month, the following additional maintenance procedures must be carried out and a record kept:

- Resistance of motor windings to earth, must be measured with a 500 V DC insulation tester each month. If these readings are less than 10 MΩ (Megaohm), the motor must be dried out in a warm airflow (typically at 40°C) and re-checked before running the motor.
- The fan should be operated between 15 and 30 minutes each month to ensure that correct lubricant conditions are maintained within the bearings (i.e., to prevent grease hardening).
- If anti-condensation heaters are fitted, check each month that they automatically switch on (i.e., they are drawing current) when the motor is switched off.

## 7. OVERHAUL / EXTENDED MAINTENANCE

Advice on motor overhaul procedures, bearing /seal replacement, motor replacement, motor rewinding, spare parts, condition monitoring, vibration analysis, refurbishment, etc. is available from Woods Air Movement service centre in Colchester.

After 40,000 hours of running, we strongly recommend that a qualified and competent electrician performs a motor "health check" (as described within Section 8, Fault finding) to determine the motor insulation condition.



**NOTE!** The motor manufacturer's specification sheets are available through Woods Air Movement. After overhaul/extended maintenance the fan assembly must be correctly installed back into its original position.

## 8. FAULT FINDING

Please refer to the safety warnings ("attention" items) stated within Section 1 and 6.



**NOTE!** Routine maintenance procedures detailed in Section 6, and Table 1 of this document are designed to help keep your fan operational and fault free.

### 8.1 ELECTRICAL

Check that electrical connections to the fan are secure and are in accordance with the wiring connection diagram.

Check that the voltage applied at each fan terminal is as specified on the fan nameplate and is balanced. Measure the current on each phase of the motor in turn and check that the current consumption is within the full load current specified on the motor or fan nameplate.

Measure each motor winding to earth, and between each winding, using a 500 V DC insulation tester. If the reading is less than 10 MΩ the reason is likely to be dampness within the motor. To dry out the motor place it in a warm dry airstream (typically at 40°C) and regularly monitor the motor until the insulation reading is restored to 10 MΩ or greater. If the reading remains at less than 10 MΩ, then this could indicate that a break-down in motor winding insulation has occurred, which may require the motor to be either rewound/overhauled.

If a smell of burnt motor insulation is detected, then please seek immediate advice from Woods Air Movement Colchester.

### 8.2 MECHANICAL

Check that there are no obstructions to the motor shaft or impeller blades, that the blades are clean, and that there are no loose components, items, or debris in the vicinity.

Rotate the motor shaft by hand. Investigate any grinding noises, internal chafing, rubbing or stiffness. If any of these defects are observed, this may indicate that bearings require lubrication or replacement.

Ensure that all fixings are secure and tightened to the correct torque values.

## 9. DISPOSAL



### NOTE!

Metal components of the fan/motor should be segregated and separately recycled. The following items of material should be safely disposed of in accordance with local health and safety regulations:

- electrical lead coverings,
- motor winding insulation materials,
- bearing lubricant,
- motor/fan terminal block,
- paintwork,
- plastic parts,
- packing materials,
- silencer infill



**WARNING!** A face mask and gloves must be worn when handling the infill. If the infill is particularly dry or is damaged it should be damped down before disposal.

## 10. DECLARATIONS OF CONFORMITY



### EC Declaration of Conformity

Herewith we declare that the air movement equipment designated below, on the basis of its design and construction, in the form brought on to the market by us, is in accordance with the relevant health and safety requirements of the **EC Council directives on Machinery and Electromagnetic Compatibility and also ecodesign requirements for energy-related products**. If alterations are made to the machinery without prior consultations with us, this declaration becomes invalid. We further declare that the equipment identified below may be intended to be assembled with other equipment/machines to constitute machinery, which shall not be put into service until the assembled machinery has been declared in conformity with the provisions of these EC Council directives.

Designation of equipment:	<b>Industrial Cooling Fans</b>
Series / type:	
Fläkt Woods Limited order no:	
Relevant EC Council directives:	Machinery Directive (2006/42/EC), Electromagnetic Compatibility Directive (2014/30/EU) where applicable (1) Energy-related products Directive (2009/125/EC) relevant implementing measures: REGULATION (EU) No 327/2011, REGULATION (EU) No 1253/2014, where appropriate
Applied harmonized standards in particular (2):	EN ISO 12100:2010, EN 60204-1:2018, EN ISO 12499:2008, EN ISO 5136:2010 EN ISO 5801:2017, EN ISO 13350:2015, EN IEC 61000-6-2:2019, EN 61000-6-1:2007 EN 61000-6-3:2007/A1:2011/AC:2012, EN 61000-6-4:2007/A1:2011
Applied national standards and technical specifications in particular (3):	BS 848.2-1:2004 (BS ISO 13347-1:2004/A1:2010) BS 848.6:2003 (BS ISO 14695:2003) BS 848.7:2003 (ISO 14694:2003/A1:2011)
Basis of self attestation:	Quality Assurance to BS EN ISO 9001:2015 BSI Reg Firm Cert No. FM 155.
Technical file compiled by:	Ömer Tüzer FläktGroup Holding GmbH, Bahnhofstr. 65-71, 44623 Herne, Germany
Signed for and on behalf of the manufacturer by:	 Place: Colchester Date: 03/10/2023
Position of signatory:	Stéphane Maravel Chief Officer Woods

Notes:

- (1) Fläkt Woods fans are driven by AC induction motors which are inherently compliant if supplied with a truly sinusoidal AC supply. Where the fan motor is supplied via an inverter or other electronic control, verification of its compatibility together with cabling should be sought from the control supplier.
- (2) For a complete list of applied standards and technical specifications see Fläkt Woods documentation.
- (3) Where no relevant harmonised standards exist.

Fläkt Woods Limited t/a Woods Air Movement  
Axial Way  
Colchester CO4 5ZD  
United Kingdom  
Tel: +44 (0) 1206 222555  
Email: [customerservices.woods@flaktgroup.com](mailto:customerservices.woods@flaktgroup.com)  
Website: [www.woodsairmovement.com](http://www.woodsairmovement.com)

Registered in England no. 233771  
Registered office: Axial Way, Colchester, CO4 5ZD, United Kingdom  
© Fläkt Woods Limited October 2023





### UKCA Declaration of Conformity

Herewith we declare that the air movement equipment designated below, on the basis of its design and construction, in the form brought on to the market by us, is in accordance with the relevant health and safety requirements of the **UK Parliament Regulations on Product Safety, Electromagnetic Compatibility and Ecodesign for Energy-Related Products**. If alterations are made to the machinery without prior consultations with us, this declaration becomes invalid. We further declare that the equipment identified below may be intended to be assembled with other equipment/machines to constitute machinery, which shall not be put into service until the assembled machinery has been declared in conformity with the provisions of these UK Parliament Regulations.

Designation of equipment:	<b>Industrial Cooling Fans</b>
Series / type:	
Fläkt Woods Limited order no:	
Relevant UK Regulations:	Supply of Machinery (Safety) Regulations 2008 Electromagnetic Compatibility Regulations 2016 where applicable (1) Ecodesign of energy-consuming products relevant implementing measures: REGULATION (EU) No 327/2011, REGULATION (EU) No 1253/2014, where appropriate
Designated standards in particular (2):	EN ISO 12100:2010, EN 60204-1:2018, EN ISO 12499:2008, EN ISO 5136:2010 EN ISO 5801:2017, EN ISO 13350:2015, EN IEC 61000-6-2:2019, EN 61000-6-1:2007 EN 61000-6-3:2007/A1:2011/AC:2012, EN 61000-6-4:2007/A1:2011  BS ISO 13347-1:2004/A1:2010, BS ISO 14694:2003/A1:2011, BS ISO 14695:2003
Basis of self attestation:	Quality Assurance to BS EN ISO 9001:2015 BSI Reg Firm Cert No. FM 155.
Technical file compiled by:	Iain Kinghorn Fläkt Woods Limited, Axial Way, Colchester, CO4 5ZD, United Kingdom
Signed for and on behalf of the manufacturer by:	 Place: Colchester Date: 06/10/2023
Position of signatory:	Stéphane Maravel Chief Officer Woods

Notes:

- (1) Fläkt Woods fans are driven by AC induction motors which are inherently compliant if supplied with a truly sinusoidal AC supply. Where the fan motor is supplied via an inverter or other electronic control, verification of its compatibility together with cabling should be sought from the control supplier.
- (2) For a complete list of applied standards and technical specifications see Fläkt Woods documentation.

Fläkt Woods Limited t/a Woods Air Movement  
Axial Way  
Colchester CO4 5ZD  
United Kingdom  
Tel: +44 (0) 1206 222555  
Email: [customerservices.woods@flaktgroup.com](mailto:customerservices.woods@flaktgroup.com)  
Website: [www.woodsairmovement.com](http://www.woodsairmovement.com)

Registered in England no. 233771  
Registered office: Axial Way, Colchester, CO4 5ZD, United Kingdom  
© Fläkt Woods Limited October 2023

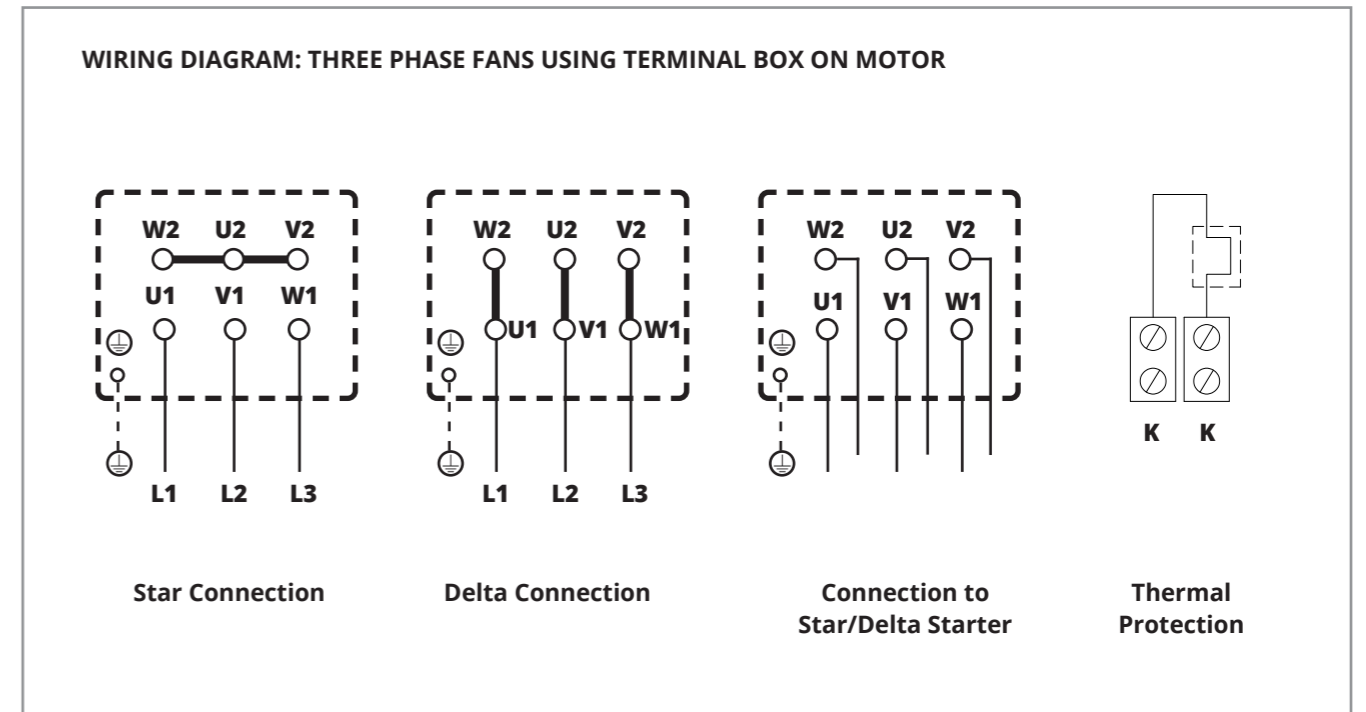

**TABLE 1**

Routine Maintenance Schedule	Every 6 Months	Every 12 Months	Comments
1. Examine fan guards (if fitted)	✓		Remove any debris that may have accumulated round or on the guard surface.
2. Examine motor cooling fins	✓		Remove any material or dirt which has build-up between the motor cooling fins.
3. Examine impeller for dirt build-up or any physical damage	✓		Remove any build-up of dirt. Ensure impeller is secure. Replace impeller if it is damaged.
4. Check condition and tautness of fan safety support chains/harnesses/ropes (if fitted)	✓		Clean and inspect safety supports. Replace if there is any deterioration / corrosion detected.
5. Examine and operate vibration sensors (if fitted), and temperature sensors (if fitted)	✓		Check operation using built-in sensor test features or dummy signals. Check that the fan is automatically switched off, or that a warning indication is provided, when the sensors / switches indicates a fault.
6. Examine condition of safety guards (if fitted) and associated fixings	✓		Clean safety guards. Replace if there are any signs of excessive corrosion or damage
7. Check for condensation build up in the motor	✓		Remove the drain plugs and check for levels of condensate (see Section 4)
8. Check operation of anti-condensation heaters (if fitted)	✓		Switch off power to the motor. Check that the anti-condensation heater is energised (i.e. it is drawing current).
9. Examine the clearance between the fan impeller blade tips and fan duct. Check the angle, and the security of the impeller blades		✓	Ensure that the gap between the impeller blade ends and the fan duct is even and adequate. If in doubt, please contact Woods Air Movement for advice related to blade tip gap. Ensure that the impeller blades are secure. Blade angle must not be changed before contacting Woods Air Movement for advice.
10. Check torque of fixings used to secure the fan to its support structure.		✓	It is essential to confirm that all fixings are properly fitted, are tight, and are fully driven home (see Figure 2a and 2b). If in doubt, please contact Woods Air Movement for advice related to the torque value of a particular fixing.
11. Examine motor, fan and ancillary equipment fixings		✓	It is essential to confirm that all fixings are properly fitted, are tight, and are fully driven home (see Figure 2a and 2b) If in doubt about the torque of a fixing contact Woods Air Movement for advice.
12. Check movement (deflection) of vibration isolators (if fitted)		✓	Check freedom of movement. Tighten anti-vibration mount fixings if necessary.
13. Check motor voltage and current consumption		✓	Ensure voltage and full load current are as specified on the motor nameplate
14. Inspect paintwork / galvanising finish		✓	Treat any areas of damage with suitable anti-corrosion paint.
15. Lubricate motor bearings		✓	Check requirement in accordance with Section 6.2
16. Check fan assembly wiring		✓	Check security and condition of all wiring (including the earth).
17. Check fan operation for excessive vibration levels		✓	Vibration levels, whilst the fan is operating, should not be excessive. If levels are seen to have increased since the previous inspection, the fan must not be operated until the root cause has been identified and rectified.

**3-PHASE**

**FIGURE 1**



**FIGURE 2a**

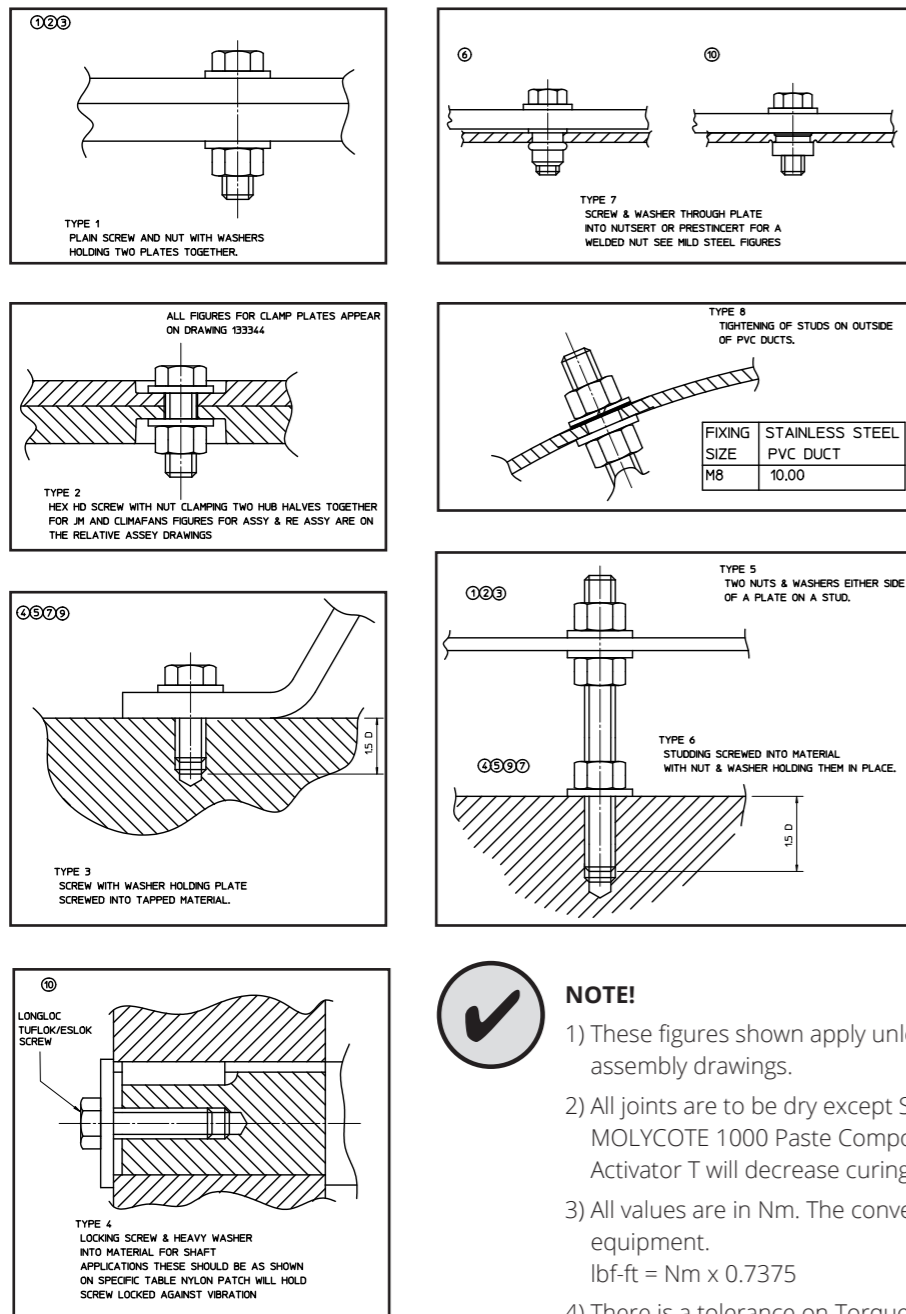

**NOTE!**  
The numbers show thus ⊗ in the boxes are to show the screw types and tapped materials which are applicable to the diagram shown.



**NOTE!**

- 1) These figures shown apply unless shown otherwise on specific assembly drawings.
- 2) All joints are to be dry except Stainless Steel which is to have MOLYCOTE 1000 Paste Compound, prior treatment of Loctite Activator T will decrease curing time if necessary.
- 3) All values are in Nm. The conversion factor is given for lbf-ft equipment.  
 $lbf-ft = Nm \times 0.7375$
- 4) There is a tolerance on Torque Wrenches up to  $\pm 5\%$ .
- 5) Nuts are to be tightened only once so no overtightening can occur.
- 6) The head of the Screw makes no difference to torque figures other than how the torque is supplied. The Screw or Base Material are the important factors for torque.
- 7) When using two materials always use the lowest figure of the two.
- 8) The figure to be used on AEG Capacitor Studs is 4 Nm.
- 9) The material being clamped is only to be taken into consideration if it is Hollow, very Ductile or Plastic. Please seek advice where necessary.

**FIGURE 2b**

**TABLE OF TORQUE SETTINGS FOR FIXINGS (DRAWING NO: D248284)**

FIXING SIZE	① STEEL 8.8	② STAINLESS STEEL A2,A4 PROP 70	③ M.S. FIXINGS NOT 8.8 GRADE INCLUDES T BOLTS	④ STEEL INTO TAPPED M.S.	⑤ STEEL INTO EXTRUDED AL	⑥ NUTSERT	⑦ SCREW INTO CAST ALUM ALSO SEE MOTOR TABLE BELOW	⑧ TAPTITE SELF FORMING	⑨ INTO CAST IRON ALSO SEE MOTOR TABLE BELOW	⑩ STAINLESS STEEL A2,A4 PROP 80	PRESTICERT
M1.6	0.2000	----	0.1000	0.1000	----	----	----	----	0.050	----	----
M2	0.4000	----	0.2000	0.2000	----	----	----	0.400	0.100	----	5
M3	1.5000	0.9000	0.8000	0.8000	----	1.50	----	1.400	0.400	1.2	6
M4	3.5000	2.0000	2.0000	2.0000	----	3.50	----	3.000	1.000	2.7	9
M5	7.0000	3.9	3.5000	3.5000	----	7.00	----	6.000	1.750	5.3	11.5
M6	12.000	6.9	6.0000	6.0000	5.00	12.00	7.00	10.000	3.000	9.2	12
M8	28.000	17.0	15.000	15.000	10.00	28.00	14.00	25.000	7.500	22.0	21
M10	55.000	33.0	30.000	30.000	20.00	40.00	28.00	55.000	15.000	43.0	23
M12	100.00	56.0	50.000	50.000	36.00	55.00	50.00	95.000	25.000	75.0	35
M14	155.00	89.0	80.000	80.000	60.00	----	85.00	----	40.000	119.0	----
M16	245.00	136.0	120.00	120.00	95.00	----	135.00	----	60.000	181.0	----
M18	335.00	191.00	170.00	170.00	----	----	----	----	85.000	254.0	----
M20	475.00	267.00	240.00	240.00	178.00	----	200.00	----	120.000	356.0	----
M22	645.00	364.00	325.00	325.00	245.00	----	300.00	----	----	485.0	----
M24	820.00	460.00	410.00	410.00	310.0	----	420.00	----	450.000	613.0	----
M27	1200.0	671.00	600.00	600.00	----	----	----	----	----	895.0	----
M30	1640.0	915.00	820.00	820.00	----	----	----	----	----	1220.0	----
M33	2225.0	----	1115.0	1115.0	----	----	----	----	----	----	----
M36	2855.0	1600.00	1425.0	1425.0	----	----	----	----	----	2121.0	----
M39	3700.0	----	1850.0	1850.0	----	----	----	----	----	----	----
M42	4565.0	----	2285.0	2285.0	----	----	----	----	----	----	----
M45	5690.0	----	2840.0	2840.0	----	----	----	----	----	----	----

⑧ **NOTE** that Taptite screws may need a high torque to start the thread forming process

**TYPE 9**

Special arrangement of locking impeller blade into hub. For this application see specific assembly DRG only for correct torque figures.

The torque wrenches should be set to QCP/002 that is  $\pm 5\%$

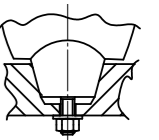

**BINX NUTS**

Binx Nuts Grade 6 are unmarked and should be tightened to torque value specified for Mild Steel fixings (all sizes). Binx Nuts Grade 8 should be tightened to torque value specified for Grade 8.8 fixings.

**RUBBER A/V**

Where a rubber grommet or flexible mount is used a metal spacer tube or metal insert should be supplied. The rubber should never be crushed by the fixings for any special application seek advice from technical support.

**NOTE!**

Brass fixings have half the shear strength of cast iron so use half the figures for tapped cast iron.

PAD AND FOOT MOUNT TORQUE SETTINGS					
ON HOLLOW FOOT USE LOAD SPREADING WASHERS AND SAME TORQUE AS SOLID FOOT					
FRAME SIZE	THREAD/HOLE	MOTOR PAD TO ARM		FOOT MOUNT	
		ALUMINIUM	CAST IRON	ALL	WASHER
TORQUE SETTING IN Nm					
D63/71	M8 TAPSITE	20-25	20-25	20-25	
M8 TAPSITE REASSEMBLY		15	15		
D63/71	M8	15	15		
	M10	35	35	50	
D80	M12	55	55	85	83770
D90	M12	55	55	85	1504
D100	M12	55	55	85	411590
D112	M12	55	55	85	411590
D132	M16	135	135	180	251691
D160/180	M20	240	240	350	251692
D200 - 315	M24		450	450	267652
LARGER	M24		450	450	

**NOTE**

All foot mounted motor fixings should be applied with Loctite compound. For any fixings exceeding M24 please contact Engineering for details. At least x1.5D thread engagement available for cast iron motors and x2D for aluminium motors. If insufficient contact Engineering.

TABLE 10 SHAFT END FIXINGS		
MOTOR SIZE	THREAD SIZE	TORQUE VALUE
BT4, 5 & 9		
CT5, CT9 & D80	M6	006.000
D90S & D90L	M8	015.000
F22, D100L & D112M	M10	030.000
D132S, D132M	M12	050.000
D160M, D160L		
D180M, D180L	M16	120.000
D200L, D225S		
D255M, D250S,		
D250M, D280S	M20	180.000
D280M, D315S		
D315M		
D315 ABB	M24	295.000
LARGER	M24	295.000





Woods Air Movement delivers smart and energy efficient Air Movement and Fire Safety solutions to support every application area. We offer our customers innovative technologies, high quality and outstanding performance.

The widest range of Air Movement and Ventilation products in the market, and strong market presence with over 100 years of experience and manufacturing of products, guarantees that we are always by your side, ready to deliver Excellence in Solutions.

**Contact our friendly sales team today  
for more information**

Call: +44 (0) 1206 222 555

Email: [quotations.woods@flaktgroup.com](mailto:quotations.woods@flaktgroup.com)

[www.woodsairmovement.com](http://www.woodsairmovement.com)