

ITF-EC INDUCTION THRUST FANS

WIRING DIAGRAM

Attachment: Technical Specifications Sheet. EC-ITF

A. Connection diagram OTB – Power supply/Control Interface

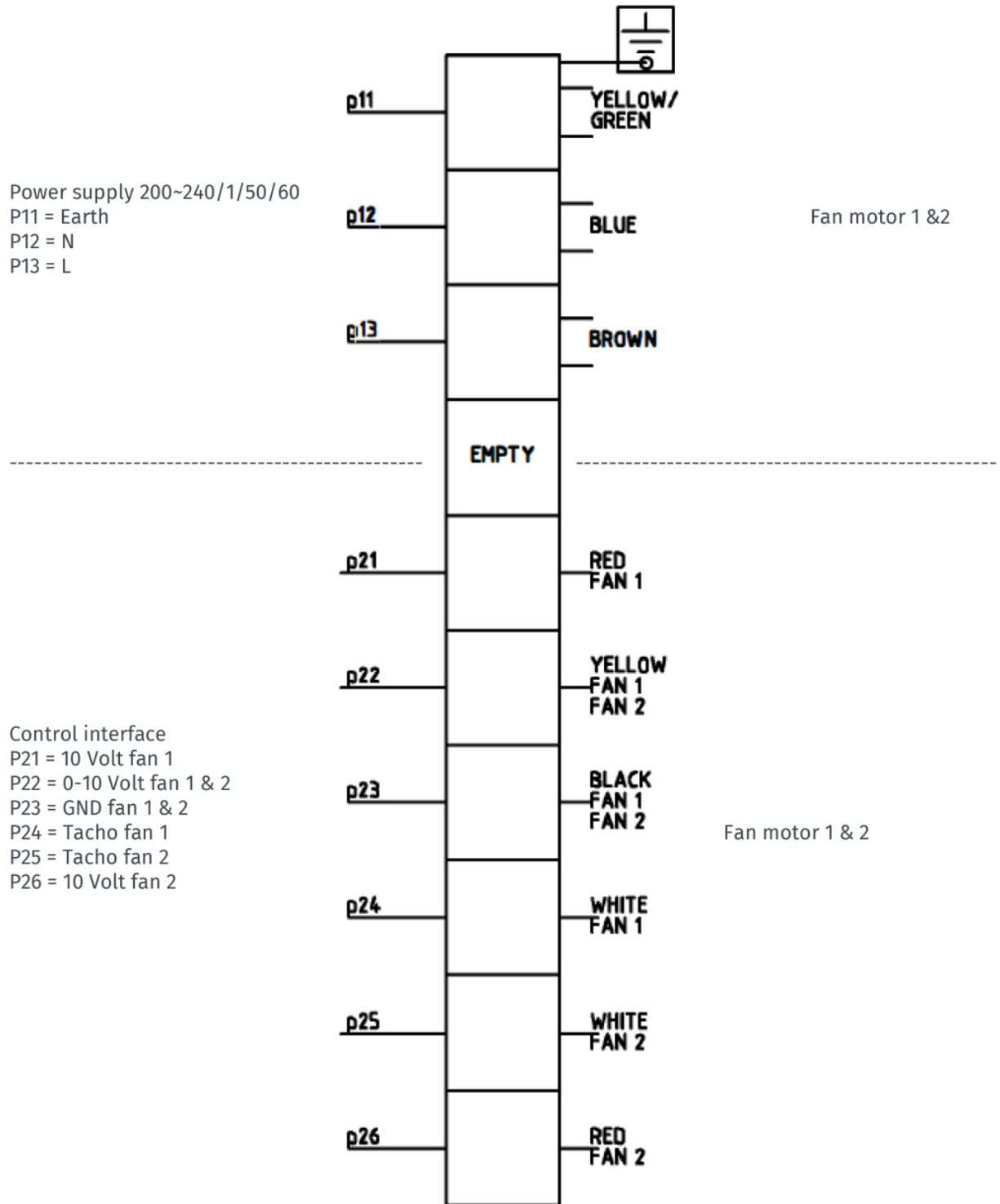

ITF-EC INDUCTION THRUST FANS

WIRING DIAGRAM

B. Airflow control settings OTB – control interface

a. Maximum airflow

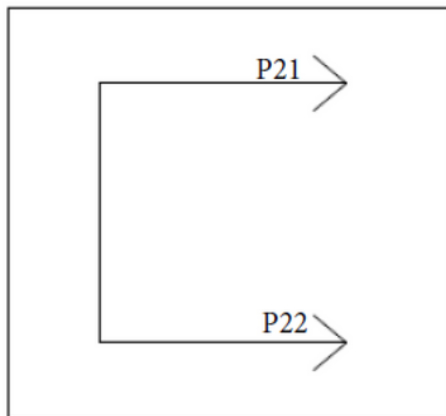

b. Airflow setting by 1-10 Voltdc setting

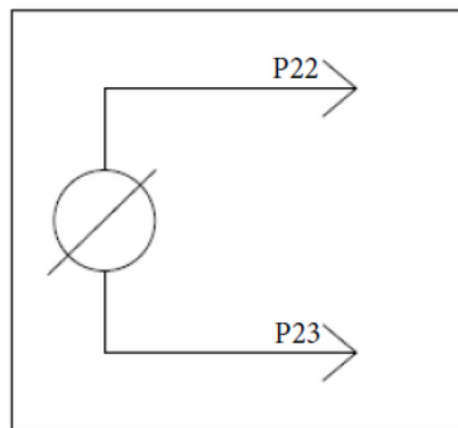

c. Airflow setting by potentionmeter

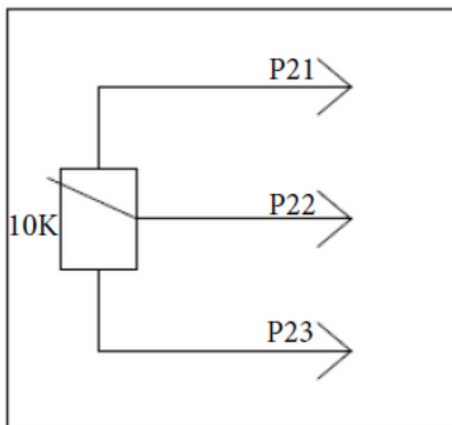

d. Airflow setting by PWM signal

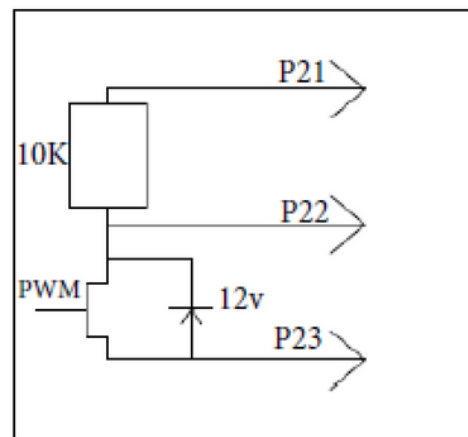

e. Tacho P24 - Fan 1
 P25 - Fan 2

C. Technical data.

Fan unit weight	16 kg	IP class:	54
n [min ⁻¹]:	2.740	Ins CL:	B, S1
P [Kw]	0,3	Operation temp:	-20~60°C
I nom. [A]	2,6		
U [V]/ph/F [Hz]	200~240/1/50/60		