

WOODS EC TWIN AND SINGLE BOX FANS (3PH)

Safety, Installation and Maintenance Instructions

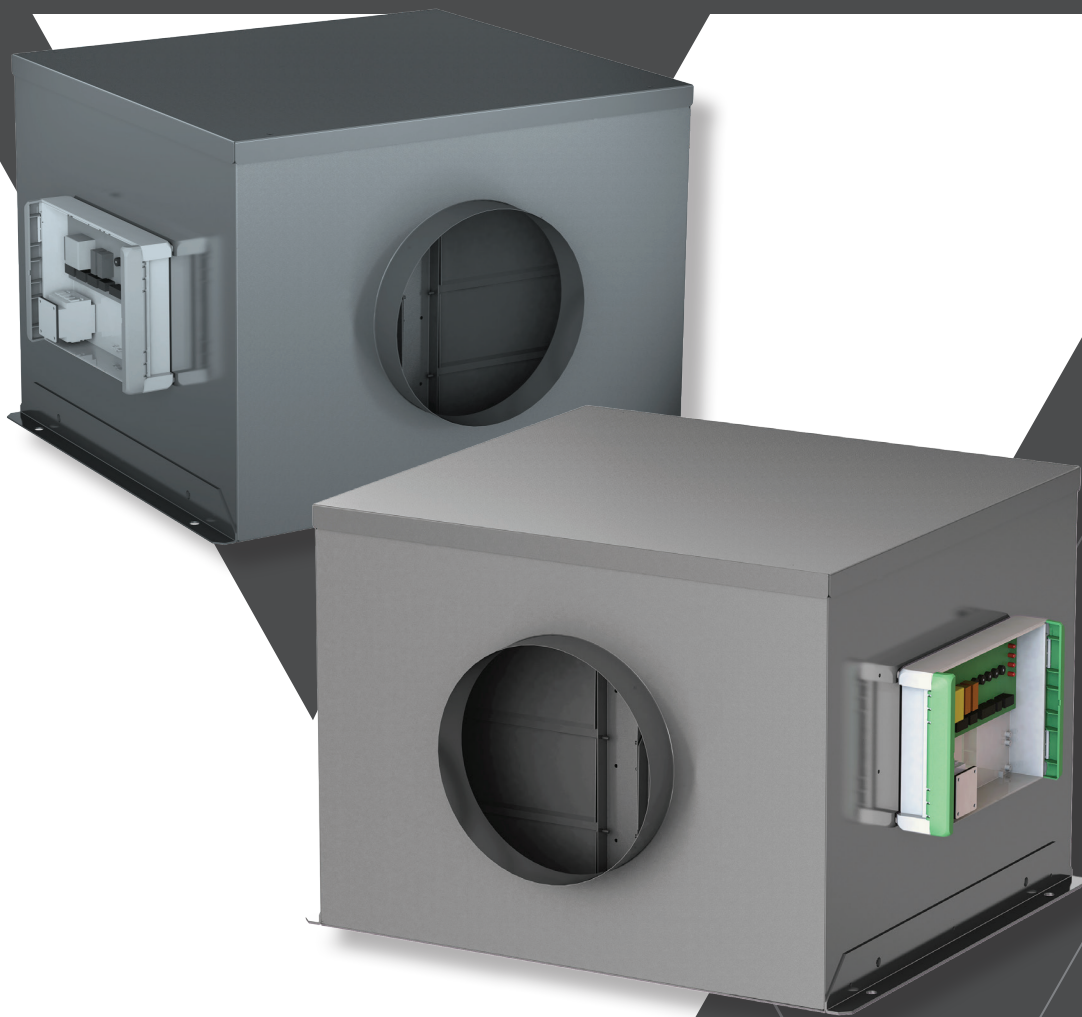

CONTENTS

	PAGE
1. INTRODUCTION	3
2. GENERAL CONSTRUCTION	3
3. INSPECTION UPON RECEIPT OF GOODS	3
4. HANDLING	3
5. INSTALLATION	3
6. SAFETY	3
7. AMBIENT TEMPERATURES	3
8. MOUNTING	3
9. POSITIONING	3
10. DUCT CONNECTIONS	4
11. ACCESS	4
12. ELECTRICAL WIRING	4
13. MAINTENANCE	4
14. FAN WIRING	4
15. ACO-3PHASE	5
16. FAULT CONDITION	5
17. IN THE CASE OF FAULT CONDITION	5
18. VOLT FREE CONTACTS	5
19. DECLARATION CERTIFICATE	6

1. INTRODUCTION

Designed for internal and external applications, the Woods EC Twin & Single box fan range encompasses models of direct driven centrifugal fan units with airflow duties up to 3.8m³/s.

Motor windings are fitted with an auto-reset thermal cut-out.

Motors are pre-wired to an external terminal box speed controller, auto-changeover & isolator

2. GENERAL CONSTRUCTION

Casework is manufactured from 0.9mm to 1.2mm thick galvanised sheet steel with an 'O' class foam / barrier mat insulation to provide acoustic insulation. Access is via a removable top cover. Fitted backdraught shutters prevent recirculation via inoperative fan.

Discharge via optional bird-mesh protected discharge cowl.

3. INSPECTION UPON RECEIPT OF GOODS

Immediately upon receipt of any goods, a careful inspection should be undertaken to ensure neither damage has occurred nor parts missing.

Particular attention should be paid to the fan impeller, motor shaft, anti-vibration mounts, flexible connection, coil connection & casework.

In the event of such damage or loss having occurred, inform supplier WITHIN 3 WORKING DAYS of the delivery date, giving the serial number which can be found on the nameplate. After this period we will be unable to entertain any claim for loss or damage.

4. HANDLING

Units being craned into position must be handled with care to avoid damage.

5. INSTALLATION

When installing our equipment, the following instructions below must be observed.

6. SAFETY

It is the responsibility of the installer to ensure that the installation complies with the legal regulations and the current HEALTH AND SAFETY AT WORK ACT.

7. AMBIENT TEMPERATURES

The range of units covered by this manual are designed for use in an environment where the ambient air temperature is unlikely to exceed 60°C.

8. MOUNTING

These units must be mounted in the horizontal plane. Bottom access can be accommodated if advised at time of order. These fans are not suitable for inverted mounting on to the ceiling.

9. POSITIONING

All units should be mounted on a completely flat base.

Mounting brackets are provided with the units.

10. DUCT CONNECTIONS

Adjoining ductwork should always be independently supported to avoid undue stress on the unit casing. Impellers are statically and dynamically balanced, anti-vibration mounts and fast clamps are available to suit.

11. ACCESS

All units are designed with easily removable components for maintenance purposes. Sufficient room should be kept to allow components to be withdrawn.

12. ELECTRICAL WIRING

Electrical supply must be fully isolated before attempting to affect any work on the unit.

All wiring should be carried out by a competent electrician and should comply fully with the current I.E.E. Wiring regulations.

The electrical supply must be as stated on the nameplate.

When the wiring is complete, check for free & correct rotation of the fan impeller

13. MAINTENANCE

6 MONTHLY

The fan impeller should be carefully cleaned with a brush. This will prevent the impeller from becoming unduly dirty and become unbalanced.

12 MONTHLY

The security and integrity of all fastenings should be checked. Particular attention should be paid to the impeller fixing onto the fan shaft.

14. FAN WIRING

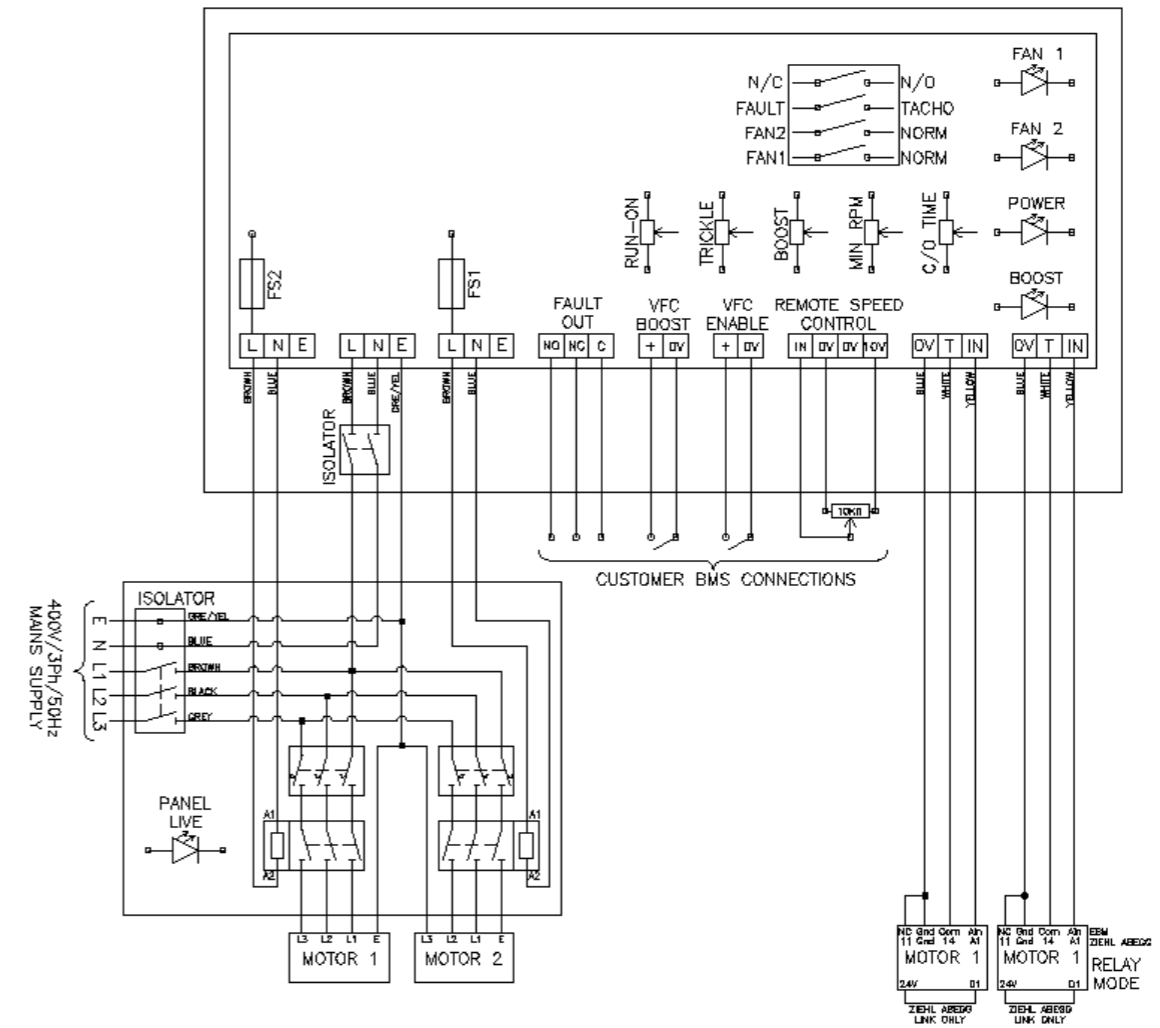
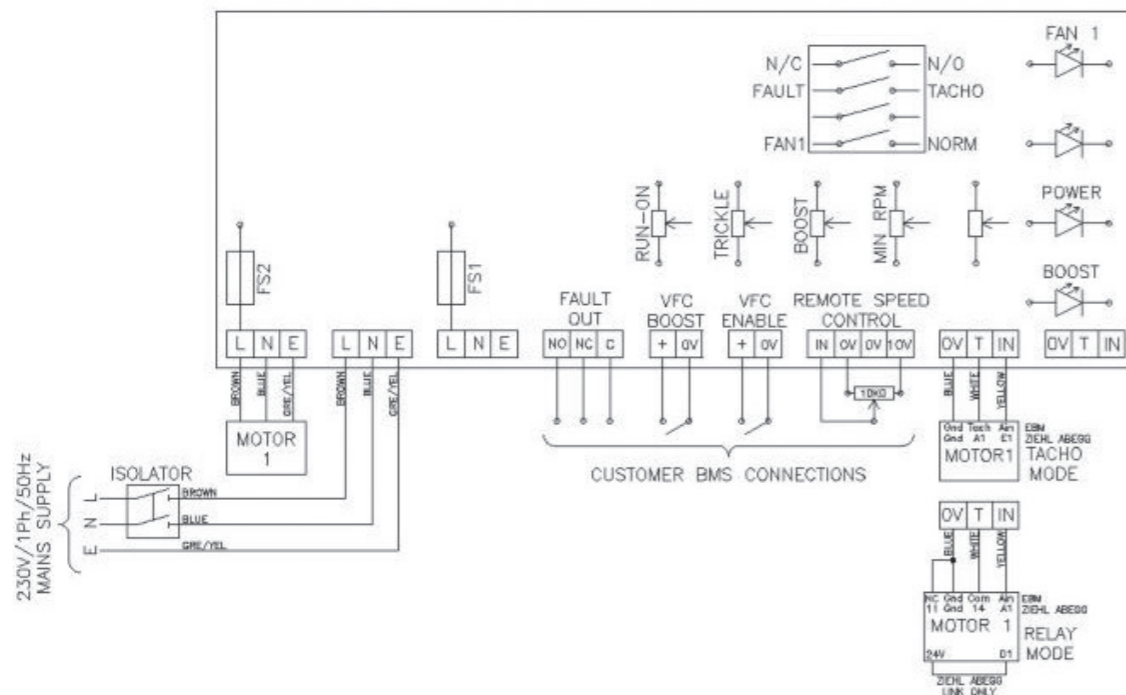

15. ACO-3PHASE

Using the switch on the front panel, select either Fan A or Fan B as the duty fan.

16. FAULT CONDITION

- The changeover senses overload trip in the duty motor.

17. IN THE CASE OF A FAULT CONDITION

- The indicator for the Trip motor will illuminate. The Stand-by motor will start.

18. VOLT FREE CONTACTS

These are available for use to provide remote indication to a BMS panel to indicate motor failure. Contacts are normally open and rated at 5A 230V.

19. DECLARATION CERTIFICATE



Declaration of Conformity - CE As defined by the EC Machinery Directive 2006/42/EC

Manufacturer Woods Air Movement
Axial Way
Colchester CO4 5ZD, GB

Herewith we declare that the machine:

Designation of the machine	Model or Type of machine	Since year of manufacture
Woods EC Box fan (Single & Twin)	EC Box fan	2021

Meets the basic requirements of the guidelines:

- ISO 9001-2015
- ISO 14001-2015
- QMS Cert No: 374622021

The following harmonized standards are applied:

EN 60204-1: 2018	EN ISO 12100:2010	EN ISO 13857:2008	EN 61000-3-2:2014
EN 60950-1:2006	EN 61000-3-3:2013		

The specific technical documentation in accordance with Appendix VII B has been written and is available in its entirety. The specific documentation will be transmitted to the official authorities on justified request through electronic means, on data carriers or on paper.

Name of the representative for documentation:

Address of the nominated person:

see manufacturers address

EC-Declaration of Conformity was issued:

Colchester, 31-Aug-22

Place, Date

Simon Chapman
R&D Director Woods Air Movement



Declaration of Conformity - UKCA As defined by the UK Parliament Regulations on Product Safety

Manufacturer Woods Air Movement
Axial Way
Colchester CO4 5ZD, GB

Herewith we declare that the machine:

Designation of the machine	Model or Type of machine	Since year of manufacture
Woods EC Box fan (Single & Twin)	EC Box fan	2021

Are in conformity with the following directives:

- The Eco-design for Energy-Related Products and Energy Information (Amendment) (EU Exit) Regulations 2019
- The Restriction of the Use of Certain Hazardous Substances in Electrical and Electronic Equipment Regulations 2012
- Electromagnetic Compatibility Regulations 2016
- Electrical Equipment (Safety) Regulations 2016

The specific technical documentation is in accordance with the UK Parliament Regulations on Product Safety.

Name of the representative for documentation:

Address of the nominated person:

see manufacturers address

EC-Declaration of Conformity was issued:

Colchester, 15-July-22

Place, Date

Simon Chapman
R&D Director Woods Air Movement



Woods Air Movement delivers smart and energy efficient Air Movement and Fire Safety solutions to support every application area. We offer our customers innovative technologies, high quality and outstanding performance supported by more than fifty years of accumulated industry application experience. The widest range of Air Movement and Ventilation products in the market, and strong market presence with over 100 years of experience and manufacturing of products, guarantees that we are always by your side, ready to deliver Excellence in Solutions.

**Contact our friendly sales team today
for more information**

Call: +44 (0) 1206 222 555

Email: quotations.woods@flaktgroup.com

www.woodsairmovement.com